

Pico-Grid

Installation Instructions



CONTENTS

1. Introduction
2. Your Pico-Grid Configuration
3. Safety
4. Tools Required
5. Mounting Solar Panel
6. Connecting the system
7. Pico-Grid Controller

1. INTRODUCTION

Welcome to the Clear Blue system installation guide. This document is essential for ensuring the correct setup of your system. Adherence to these guidelines is crucial as they directly impact the conditions of your warranty.

Prior to commencing the installation, it is important to acquaint yourself thoroughly with all components, their handling procedures, and all safety warnings associated with the system.

Keep this manual readily accessible for future reference and for any maintenance personnel who may require it.

Disclaimer

Clear Blue Technologies International, Inc., unless explicitly stated in writing, does not provide any warranties regarding the precision, adequacy, or appropriateness of the technical or other information contained in its manuals or other documentation. Clear Blue Technologies International, Inc. shall not be responsible or liable for any form of loss or damage, whether direct, indirect, or incidental, that may result from the utilization of such information. The use of these materials and products is at the sole risk of the user.

2. YOUR PICO-GRID CONFIGURATION

Your Pico-Grid system comprises the following components:

- 2 x 75W Solar Panels, complete with installation hardware.
- 1 x Pico-Grid Controller, accompanied by necessary hardware.

For detailed information on each component, including packaging details, please refer to the packing slip provided with your shipment.

3. SAFETY

Risk Warning: Incorrect installation or improper use of the system components may pose serious risks, including electric shock or fire.



- **Component Handling:** Under no circumstances should you disassemble or attempt to repair any components manufactured by Clear Blue. The Pico-Grid Controller, in particular, contains no user-serviceable parts.
- **Compliance with Instructions:** Adhere strictly to all guidelines regarding the use of external fuses/breakers as specified in this manual.
- **Component Compatibility:** Only utilize solar panels supplied by Clear Blue to ensure compatibility and safety.

Personal Safety Precautions:

- **Installation Conditions:** Clear Blue advises exercising extra caution during installation, especially under windy conditions. Installer safety should be a priority, and installations should be postponed if wind conditions are deemed unsafe.

Important Configuration Notice:

- **Incorrect Configuration Warning:** It is crucial to configure the Pico-Grid Controller with the appropriate POE/Load voltages. Failure to do so may lead to damage to the connected load.
- **Liability Disclaimer:** Clear Blue Technologies does not accept responsibility for any damage to loads that may occur as a result of incorrect voltage configuration. It is the installer's responsibility to ensure that all settings are correctly adjusted according to the specifications provided.







4. TOOLS REQUIRED

To ensure a smooth installation of the Pico-Grid system, the following tools are required:

- Puncture Tools
Drill and Drill bit set
or
Punch set including Prick punch
- Screwdriver set
- Wrench set (8mm Combination or 8mm Socket with Ratchet)
- Cutting Tool / Tin Snip
- Measuring Tape
- Wi-Fi enabled device. (ex. Smartphone)
- Weatherproof Electrical Tape
- Ballpein Hammer

5. MOUNTING SOLAR PANELS

For optimal performance, mount the solar panels in a location with minimal shading during the day. In the northern hemisphere, install on a south-facing roof; in the southern hemisphere, choose a north-facing roof.

Component	Qty.	Component	Qty.
Solar Panel (75W) 	2	1/16in Thick foam piece for the solar panel mount (50mm x 50mm) 	8
Solar Cable (4.5m/15ft.) 	1	Stainless steel strapping, 22Ga 1/2-inch (5ft long) 	2
MC4 Connectors Y Branch Set 	1	8" Black Mounting Tie Wrap 	3
21-inch Heavy Duty Cable tie black 	2	3/4" Masonry Nails 	3
#12 1-in long Drilling Screw with Washer for the solar panel mount 	12		
Galvanised Nails 3inch with the Washer 	20		

5.1 Mounting the Solar Panel on the roof.

5.1.1. Prior to installation, confirm the area for the solar panel layout. For two 75W Solar Panels, allocate an area measuring 1730mm x 1100mm. Ensure a gap of 250mm between the panels to accommodate steel strapping fasteners and cable routing.

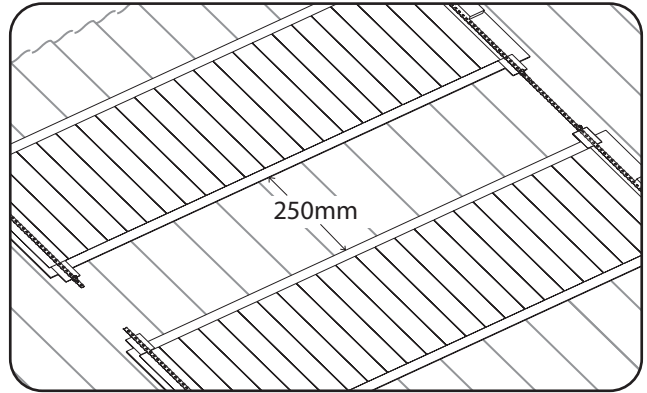

Do not remove the backing paper from the back of the solar panel if it is there.

5.2 Option 1 - Using #12- 1-inch-long drilling screw on roof.

5.2.1 Use a prick punch to mark locations for self-drilling screw holes on the roof. **Ensure these marks are positioned 30mm to 40mm from the edge of the solar panel.** Exercise caution when using a hammer during installation; **avoid striking the solar panel.**

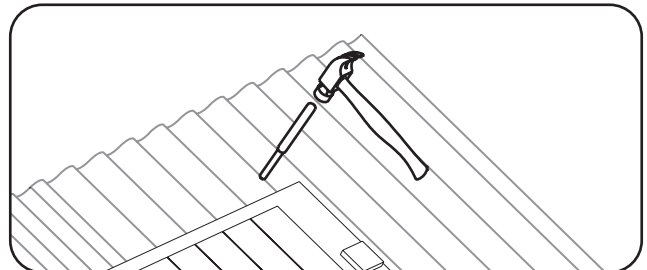

5.2.2 If a drill is unavailable, use a 3mm punch to create a hole at the marked point for the self-drilling screw. If a drill is available, use a 3mm drill bit instead.

5.2.3 Secure the #12, 1-inch-long drilling screw, along with the strapping and a 50mm x 50mm foam piece, to the roof. Utilize either an 8mm socket with a ratchet or an 8mm combination tool for this task.

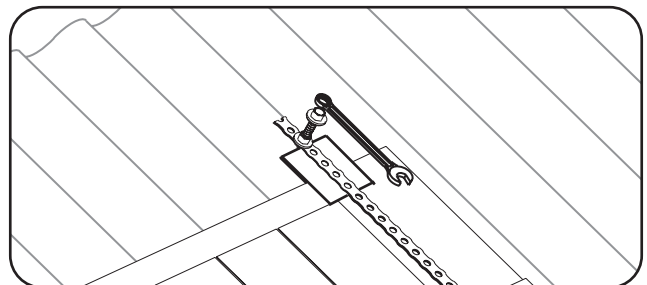

5.2.4 Pull the steel strapping taut and proceed with steps 5.3.1 to 5.3.3 on the other side

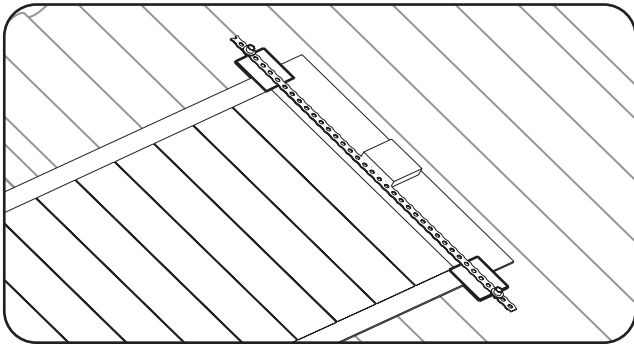

5.2.5 Use a tin snip tool to cut away any extra strapping.

5.2.6 Secure the steel strapping to the other side of the solar panel, referring to steps 5.2.1 to 5.2.5.

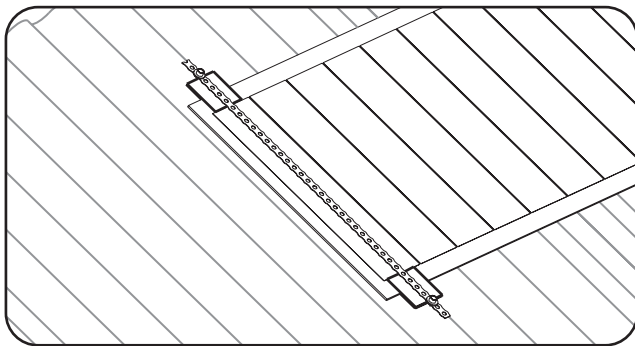

The thin-film technology of these panels ensures minimal impact on performance, even if the strapping covers a few cells.

5.3 Option 2- Using Ondura Nails 3 inch long on roof.

5.3.1 Mark the location for self-drilling screw holes on the roof using a prick punch, **positioning them 30mm to 40mm from the panel's edge**. Exercise caution with the hammer during mounting to **avoid striking the solar panel**.

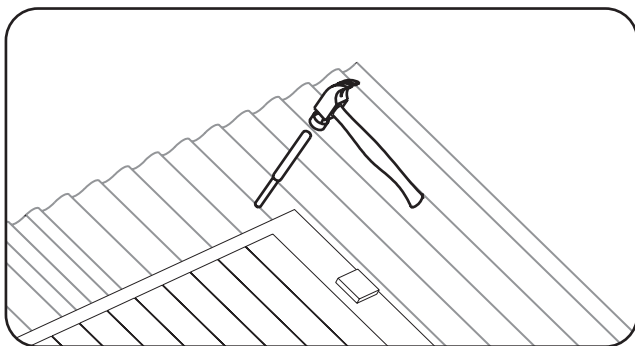

5.3.2 Secure the strapping and a 50mm x 50mm foam piece to the roof using a 3-inch Ondura Nail, employing a hammer for this purpose.

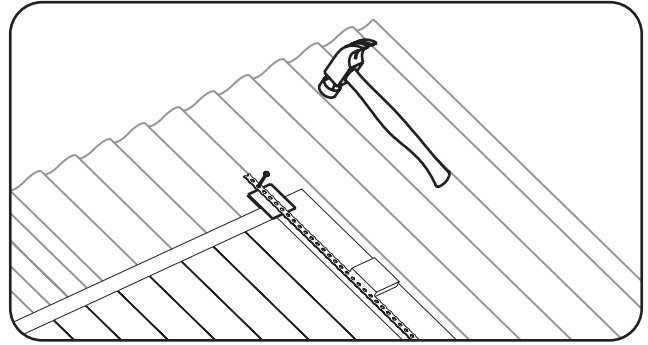

5.3.3 Pull the steel strapping taut and proceed with steps 5.3.1 to 5.3.3 on the other side

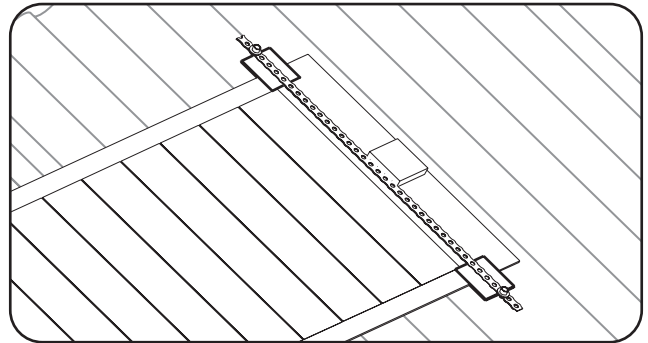

5.3.4 Use a tin snip tool to cut away any extra strapping.

5.3.5 Secure the steel strapping to the underside of the solar panel, referring to steps 5.2.1 to 5.2.5.

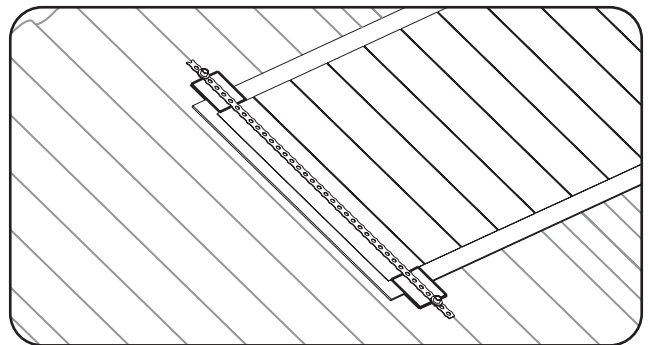

The thin-film technology of these panels ensures minimal impact on performance, even if the strapping covers a few cells.

6. CONNECTING THE SYSTEM

6.1 Connecting the Pico-Grid Controller.

Notes:

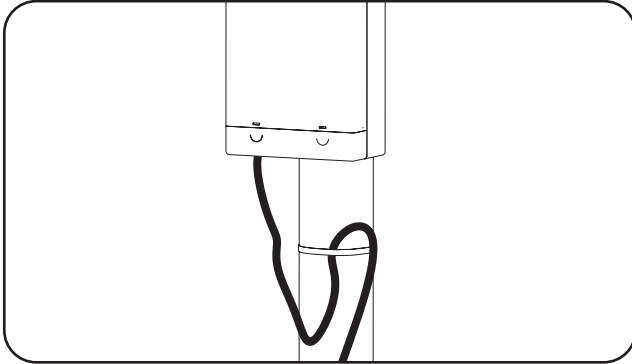

While connecting the cables, allow sufficient slack to create natural drip loops. This helps prevent water from flowing into the electronic components.

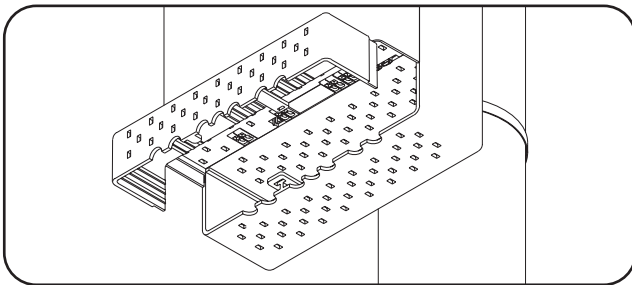

To access the ports, remove the cable access cover from the enclosure.

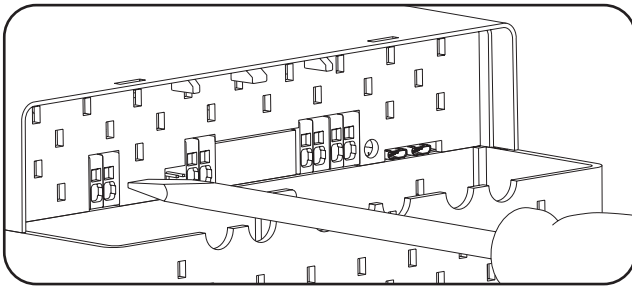

For easy wire connection to the controller, insert a flat screwdriver into the connector's release mechanism, then insert the cable, and finally remove the screwdriver.

WARNING: IT IS CRUCIAL TO CONFIGURE THE PICO-GRID CONTROLLER WITH THE APPROPRIATE POE/LOAD VOLTAGES. FAILURE TO DO SO MAY LEAD TO DAMAGE TO THE CONNECTED LOAD. USE ONLY OUTDOOR RATED POE CABLES FOR EXTERNAL INSTALLATIONS TO ENSURE SAFETY AND DURABILITY. CLEAR BLUE TECHNOLOGIES DOES NOT ACCEPT RESPONSIBILITY FOR ANY DAMAGE TO LOADS THAT MAY OCCUR AS A RESULT OF INCORRECT VOLTAGE CONFIGURATION. IT IS THE INSTALLER'S RESPONSIBILITY TO ENSURE THAT ALL SETTINGS ARE CORRECTLY ADJUSTED ACCORDING TO THE SPECIFICATIONS PROVIDED.

1. **Turn ON:** Pull the tag to remove the red plastic jumper located on the right side of the Solar port to turn ON the device.
2. **PoE Device Connection:** Select a PoE output port on the controller suitable for your device's voltage needs. Connect your PoE-compatible device to this port using an Ethernet cable.
3. **Network Link:** Use another Ethernet cable to connect the controller's second port to your network switch or router for data transfer.
4. **Solar Input:** Connect the solar panel to the controller using the provided solar panel connectors. Ensure a secure connection on the solar input.

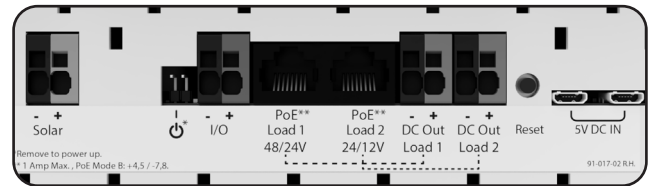





5. **Monitor:** Connect to Pico-Grid with your mobile device.
 - Scan the Connect QR code with a scanner app on your smartphone. Follow the prompts on your device to connect to the controller's Wi-Fi network. You can also connect manually to the controller, the WiFi name and password can be found on the label near the connectors.
 - Open your browser and go to "<https://192.168.4.1>" or scan the Monitor QR Code to open the web application. Here you can monitor power and configure the controller.
6. **Commission:** After connecting via Wi-Fi Direct, open the web application
 - Within the web application. An "Install" button will be located at the top left.
 - Locate the admin password on the controller, below the WiFi Password. Enter this password to proceed.
 - Voltage Selection: Choose the appropriate voltage for connected devices.
 - Power Management: Enable or disable power on required PoE ports.
 - Wi-Fi Configuration: Configure the device to connect to the local Wi-Fi network and add additional information.
 - System Scan: Run the scanning tool to check if all components are functioning correctly and if the setup is optimal.

All set! You can now disconnect from the Pico-Grid WiFi.

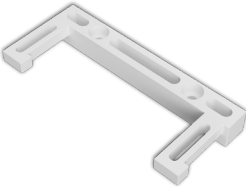

Monitor QR Code

7. PICO-GRID CONTROLLER

Component	Qty.
Picogrid Controller 	1
Steel Tie for Pole Mount 	1
Releasable Nylon Cable Ties 21", Black for Pole Mount 	3
Wall Mount Bracket 	1
1/4 inch-Hex Head 1-3/4in Long Blue Carbon Steel Anchor screw for Wall mount 	2
#7 Phillips Flat Head 2-1/2in Set screw 	1

7.1 Pole Mount Option

- **Orientation:** Mount the Pico-Grid Controller on the pole using the provided hardware, ensuring the bottom cover faces downward. This position, with connectors pointing down, protects against condensation and water entering the unit.
- **Securing the Controller:** Once pulled, the steel tie is non-releasable. Use a tin snip tool for removal if necessary. For installations requiring frequent removal, opt for releasable nylon cables instead of steel ties.

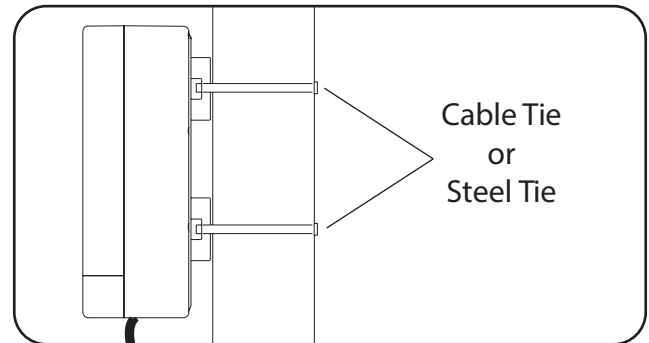

7.2 Wall Mount Option

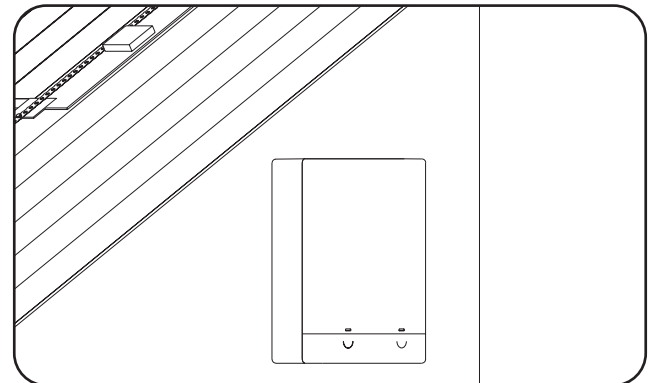

7.2.1 Utilize a prick punch to mark the positions for two holes (top and bottom), aligning them with the wall mount bracket. Confirm that the bracket is level before proceeding.

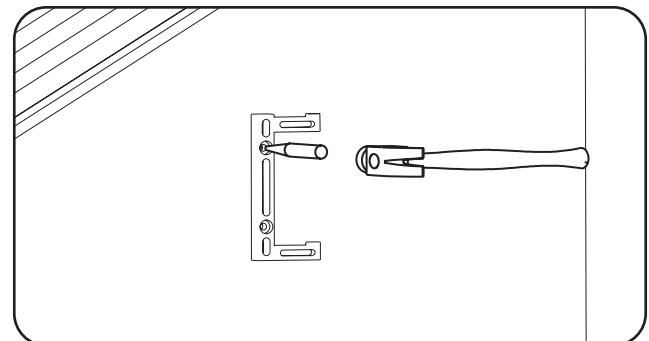

7.2.2 If a drill is not available, use a 4mm punch to create two 35mm deep holes at the marked positions. Alternatively, if a drill is available, use a 4mm drill bit for this task.

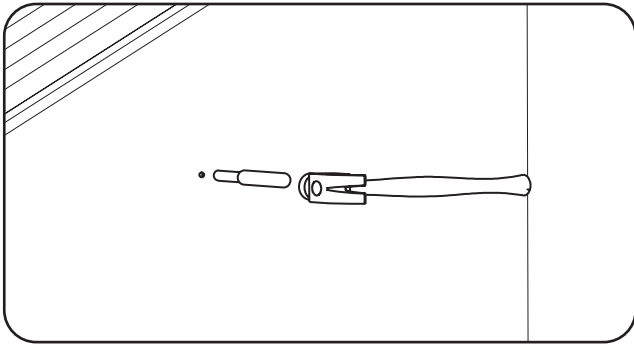

7.2.3 Secure the wall mount bracket using two ¼-inch Hex head screws. These screws can be installed with either a screwdriver or an 11mm socket wrench. Ensure the hooks on the bracket are facing to the right, as shown in the picture.

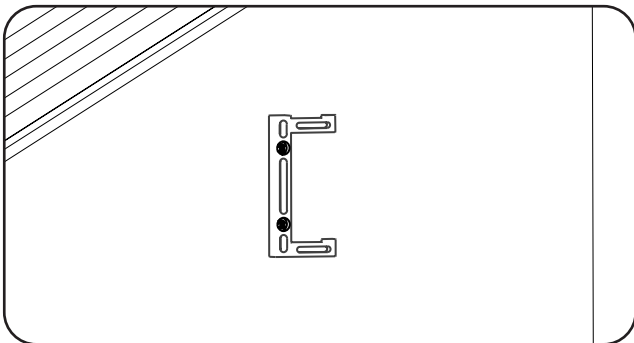

7.2.4 Insert the 2-12" long set screws into the designated holes at the bottom of the controller mounting blocks. These screws should not be fully tightened at this stage and should not go beyond the other wall; they are meant to assist in the final tightening process in step 7.2.6.

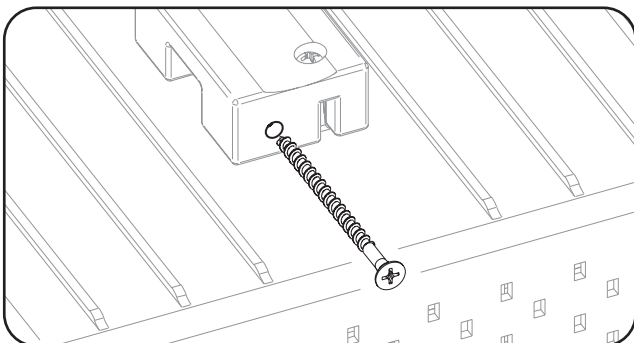

7.2.5 Slide the Pico-Grid Controller onto the wall mount bracket. Once it reaches its furthest sliding position, gently pull the controller downwards to secure it in place correctly.

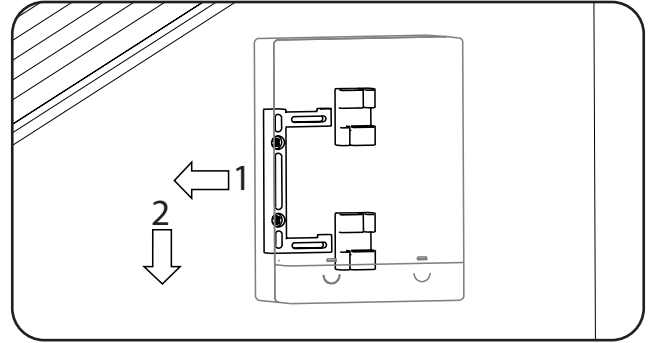

7.2.6 Once the Pico-Grid Controller is mounted, tighten the set screw to ensure the Controller remains firmly in place and does not move.

7.2.7 Use the provided 8-inch Mounting Tie Rap to bundle and secure your cables, providing effective strain relief and drip loop. Then, utilize the Masonry nails to firmly mount this tie-wrapped cable bundle onto the wall.

Contact US

At Clear Blue, we prioritize simplicity and ease of implementation in our technology. Should you have any questions or comments about this manual or our products, please feel free to contact our office for assistance

Contact Information

Telephone: +1-657-748-4822, ext. 300

Address:

30 Lesmill Rd., Unit #7

Toronto, ON

Canada

M3B 2T6

Web Support:

www.clearbluetechnologies.com/contact

Email Support:

support@clearbluetechnologies.com

Clear Blue Technologies International, Inc. reserves the right to revise and update this document at any time, ensuring that our information remains current and accurate.